



HYMAX[®] FLANGE ADAPTOR* AND HYMAX LONG BODY FLANGE ADAPTOR (1.5"-60")

HYMAX[®]
Repair the past. Connect the future.

PRODUCT SPECIFICATIONS

FEATURES

- USING THE GAME-CHANGING HYMAX TECHNOLOGY, PROVEN IN OVER 1M INSTALLATIONS IN THE US
- SUITABLE FOR ALL TYPES OF PIPES - DUCTILE IRON, CAST IRON, STEEL, COPPER, PE, PVC, AC, GRP
- PATENTED HYDRAULICALLY-ASSISTED GASKET WITH 2-STAGE SEALING
- LIGHTWEIGHT CONSTRUCTION ENABLES FAST AND EASY INSTALLATION
- ALLOWS 4° DYNAMIC DEFLECTION, REDUCING FUTURE PIPE DAMAGE

SPECIFICATIONS

STANDARDS

HYMAX FLANGE ADAPTOR AND LONG BODY FLANGE ADAPTOR MEET OR EXCEED REQUIREMENTS OF STANDARDS: AWWA C219, NSF-61 AND NSF-372.

SIZE/LENGTH

AVAILABLE IN NOMINAL DIAMETER FROM 1.5"-24" STANDARD. 26"-60" MTO (MADE TO ORDER). CONTACT KRAUSZ FOR DETAILS.

MATERIALS

FLANGED BODY

1.5"-12" ASTM A53 GRADE A STEEL.
14"-60" ASTM A283 / A283M GRADE C STEEL.

FLANGE

1.5"-2" OVAL FLANGE FOR FLOW METER.
3" MEETS ANSI B16.5.
4"-24" MEETS AWWA CLASS D.
26"-60" CONTACT KRAUSZ FOR DETAILS.

END RINGS

1.5"-12" ASTM A283 / A283M GRADE C STEEL.
14"-16" ASTM A283 / A283M GRADE C STEEL.
(OR DUCTILE IRON CASTING ASTM A536 GRADE 60-40-18).
18"-60" ASTM A283 / A283M GRADE C STEEL.

SPHERICAL SPACERS

AISI 304 STAINLESS STEEL.

GASKET

EPDM AND NBR AVAILABLE. BOTH ARE COMPOUNDED FOR WATER AND SEWAGE, MEET INTERNATIONAL STANDARDS FOR CONTACT WITH DRINKING WATER.

BRIDGE

AISI 304 STAINLESS STEEL.

COATING

100% FUSION BONDED EPOXY FOR ENHANCED CORROSION PROTECTION. NOMINAL THICKNESS 14 MIL.

NUTS AND BOLTS

AISI 304 STAINLESS STEEL. ROLLED THREAD AND ANTI-GALLING COATING.

PRODUCT PERFORMANCE (*)

WORKING TEMPERATURE	EPDM: -20°F UP TO +125°F NBR: -4°F UP TO +125°F			
DYNAMIC DEFLECTION	UP TO 4°			
MIN. PIPE INSERTION	1.5"-12" 2.25"	14"-60" 4"		
MAXIMUM OFFSET FOR MISALIGNED PIPES	1.5"-3" 0.2"	4"-60" 0.24"		
MAXIMUM OUT OF ROUNDNESS	1.5" 0.08"	2"-3" 0.20"	4"-12" 0.31"	14"-60" 0.51"
WORKING PRESSURE	1.5"-24": 175 PSI (26"-60": CONTACT KRAUSZ FOR DETAILS)			
RATED PRESSURE	1.5"-24": 262 PSI (26"-60": CONTACT KRAUSZ FOR DETAILS)			
VACUUM TEST	12 PSI			

PRODUCT TABLES

TORQUE DATA for ND 1.5"-12"(*)

ND (inch)	EPDM (Ft- Lb)	NBR (Ft-Lb)
1.5	35	NA
2	50	50
3	50	50
4	65	75
5	65	75
5	65	75
6	65	75
8	65	75
10	65	75
10	65	75
12	65	75
12	65	75

PRODUCT CONFIGURATIONS

The product is offered in several different configurations. Note that the "xx" marking in the Cat. no. should be replaced as directed:

Part Number 874-XX

56 -> Product with EPDM gasket

57 -> Product with NBR gasket

For example:

874-XX-03008812 should be read as 874-56-03008812 for EPDM gasket and 874-57-03008812 for NBR gasket.

* NBR gasket available in sizes 2"-12"

PRODUCT TABLES

HYMAX FLANGE ADAPTOR NOMINAL SIZES 1.5"-12"

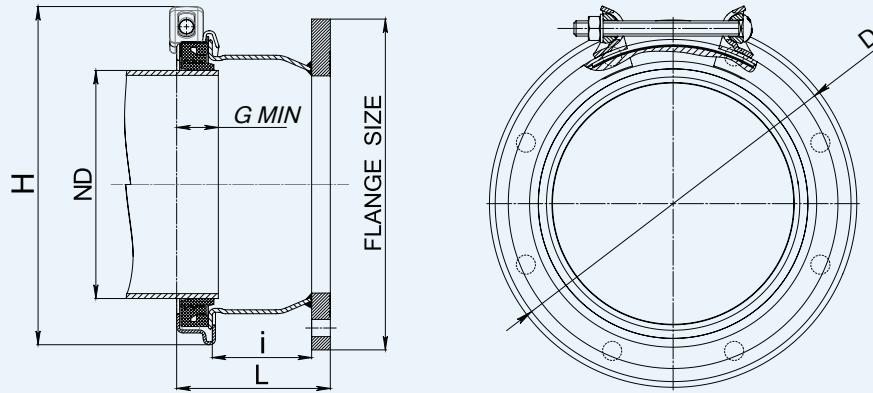

Krausz Part Number	ND (mm)	Flange (inch)	Overall Range (inch)	Before removal of inner layer (inch)	After removal of inner layer	D1 (inch)	H (inch)	i (inch)	L (inch)	D2 (inch)	B (inch)	Bolts Qty. -Size	Approx. Weight (Lbs)
874-56-01004112	1.5	1.5	1.61-2.13	1.61-1.97	1.96-2.13	Ø3.9	5.0	4.1	5.8	5.4	Ø1.95	1 -M12	7
874-XX-02005412	2	2	2.10-3.03	2.10-2.60	2.56-3.03	Ø5.2	5.7	3.7	5.7	6.0	Ø2.44	1 -M12	8
874-XX-03008812	3	3	3.46-4.33	3.46-3.90	3.86-4.33	Ø6.7	7.1	2.9	4.8	Ø7.5	Ø4.02	1 -M12	12
874-XX-04010812	4	4	4.25-5.63	4.25-5.00	4.92-5.63	Ø8.7	9.3	2.9	5.1	Ø9.0	Ø5.24	1 -M14	14
874-XX-05013012	5	5	5.12-6.38	5.12-5.75	5.71-6.38	Ø9.5	10	4	6.2	Ø10.0	Ø6.14	1 -M14	21
874-XX-06013012	5	6	5.12-6.38	5.12-5.75	5.71-6.38	Ø9.5	10	4	6.2	Ø11.0	Ø7.24	1 -M14	22
874-XX-06016312	6	6	6.42-7.68	6.42-7.05	7.01-7.68	Ø10.8	11.3	4	6.2	Ø11.0	Ø7.24	1 -M14	23
874-XX-08019012	7	8	7.48-8.74	7.48-8.11	8.07-8.74	Ø11.7	12.2	4	6.2	Ø13.5	Ø9.41	1 -M14	31
874-XX-08021712	8	8	8.54-9.84	8.54-9.17	9.13-9.84	Ø12.9	13.1	4	6.2	Ø13.5	Ø9.41	1 -M14	32
874-XX-10027212	10	10	10.70-12.00	10.70-11.37	11.33-12.00	Ø15.0	15.6	4	6.2	Ø16.0	Ø11.61	1 -M14	38
874-XX-10027812	10	10	10.96-12.26	10.96-11.63	11.59-12.26	Ø15.3	15.8	4	6.2	Ø16.0	Ø11.61	1 -M14	41
874-XX-12031512	12	12	12.40-13.66	12.40-13.03	12.99-13.66	Ø16.6	17.5	4	6.2	Ø19.0	Ø14.02	1 -M14	52
874-XX-12033412	12	12	13.15-14.41	13.15-13.78	13.74-14.41	Ø17.3	18.1	4	6.2	Ø19.0	Ø14.02	1 -M14	57

PRODUCT TABLES

HYMAX FLANGE ADAPTOR NOMINAL SIZE 14"-24"

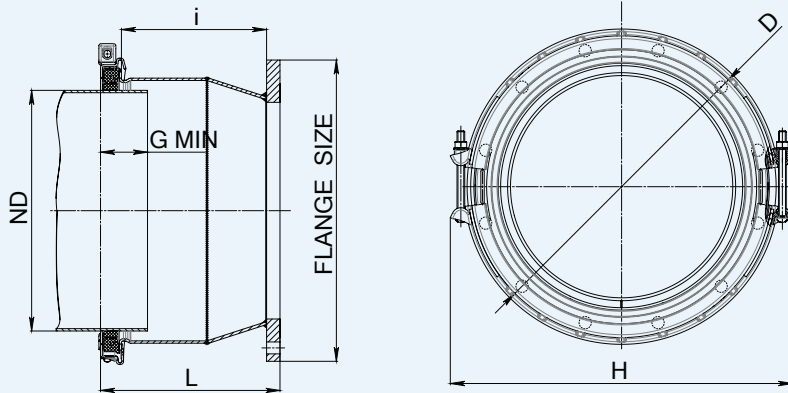

Krausz Part Number	ND (mm)	Flange (inch)	Overall Range (inch)	Before removal of inner layer (inch)	After removal of inner layer	D1 (inch)	H (inch)	i (inch)	L (inch)	D2 (inch)	B (inch)	Bolts Qty. -Size	Torque (Ft-Lbs)	Approx. Weight (Lbs)
874-56-14037812	14	14	15.00-17.10	15.00-16.10	16.02-17.10	Ø21.0	23.2	12.05	15.1	Ø21.0	Ø15.43	2 -M16	150	115
874-56-16043412	16	16	17.10-19.20	17.10-18.19	18.11-19.20	Ø23.2	25.6	12.05	15.1	Ø23.5	Ø17.91	2 -M16	150	125
874-56-18048812	18	18	19.20-21.30	19.20-20.29	20.21-21.30	Ø25.3	27.8	12.05	15.1	Ø25.0	Ø19.09	2 -M16	150	135
874-56-20054012	20	20	21.25-23.35	21.25-22.35	22.27-23.35	Ø27.3	29.8	12.05	15.2	Ø27.5	Ø21.34	2 -M16	150	155
874-56-24060612	24	24	23.85-25.95	23.85-24.96	24.88-25.95	Ø29.1	31.7	12.05	15.4	Ø32.0	Ø25.91	2 -M16	150	184
874-56-24062412	24	24	24.60-26.70	24.60-25.67	25.59-26.70	Ø30.6	33.2	12.05	15.4	Ø32.0	Ø25.91	2 -M16	150	187

HYMAX FLANGE ADAPTOR NOMINAL SIZE 26"-60"

26"-60" - MTO (MADE TO ORDER) IS AVAILABLE

PRODUCT TABLES

HYMAX FLANGE ADAPTOR LONG BODY NOMINAL SIZE 1.5"-12"

Krausz Part Number	Nominal Diameter (inch)	Flange (inch)	Overall Range (inch)	Before Removal of Inner Layer (inch)	After Removal of Inner Layer (inch)	Bolts Num. and Size (mm)	Approx. Weight (Lbs)
974-56-01004112	1.5	1.5	1.61-2.13	1.61-1.97	1.96-2.13	1 -M12	9
974-XX-02005412	2	2	2.10-3.03	2.10-2.60	2.56-3.03	1 -M12	10
974-XX-03008812	3	3	3.46-4.33	3.46-3.90	3.86-4.33	1 -M12	16
974-XX-04010812	4	4	4.25-5.63	4.25-5.00	4.92-5.63	1 -M14	23
974-XX-05013012	5	5	5.12-6.38	5.12-5.75	5.71-6.38	1 -M14	30
974-XX-06013012	5	6	5.12-6.38	5.12-5.75	5.71-6.38	1 -M14	33
974-XX-06016312	6	6	6.42-7.68	6.42-7.05	7.01-7.68	1 -M14	36
974-XX-08019012	7	8	7.48-8.74	7.48-8.11	8.07-8.74	1 -M14	42
974-XX-08021712	8	8	8.54-9.84	8.54-9.17	9.13-9.84	1 -M14	49
974-XX-10027212	10	10	10.70-12.00	10.70-11.37	11.33-12.00	1 -M14	56
974-XX-10027812	10	10	10.96-12.26	10.96-11.63	11.59-12.26	1 -M14	60
974-XX-12031512	12	12	12.40-13.66	12.40-13.03	12.99-13.66	1 -M14	61
974-XX-12033412	12	12	13.15-14.41	13.15-13.78	13.74-14.41	1 -M14	63

HYMAX FLANGE ADAPTOR LONG BODY NOMINAL SIZE 14"-24"

Krausz Part Number	ND (mm)	Flange (inch)	Overall Range (inch)	Before Removal of Inner Layer (inch)	After Removal of Inner Layer	D1 (inch)	H (inch)	i (inch)	L (inch)	D2 (inch)	B (inch)	Bolts Qty. -Size	Torque (Ft-Lbs)	Approx. Weight (Lbs)
974-56-14037812	14	14	15.00-17.10	15.00-16.10	16.02-17.10	Ø21.0	23.2	15.8	18.7	Ø21.0	Ø15.43	2 -M16	150	117
974-56-16043412	16	16	17.10-19.20	17.10-18.19	18.11-19.20	Ø23.2	25.6	15.8	18.7	Ø23.5	Ø17.91	2 -M16	150	133
974-56-18048812	18	18	19.20-21.30	19.20-20.29	20.21-21.30	Ø25.3	27.8	15.8	18.7	Ø25.0	Ø19.09	2 -M16	150	142
974-56-20054012	20	20	21.25-23.35	21.25-22.35	22.27-23.35	Ø27.3	29.8	15.8	18.8	Ø27.5	Ø21.34	2 -M16	150	151
974-56-24060612	24	24	23.85-25.95	23.85-24.96	24.88-25.95	Ø29.1	31.7	15.8	18.9	Ø32.0	Ø25.91	2 -M16	150	168
974-56-24062412	24	24	24.60-26.70	24.60-25.67	25.59-26.70	Ø30.6	33.2	15.8	18.9	Ø32.0	Ø25.91	2 -M16	150	173

HYMAX FLANGE ADAPTOR LONG BODY NOMINAL SIZE 26"-60"

26"-60" - MTO (MADE TO ORDER) IS AVAILABLE